

**CURRICULUM  
RESOURCE  
PACK**



The Tide Mill Living Museum  
Tide Mill Way, Woodbridge  
Suffolk, IP12 1BY

**01728 746959**

[woodbridgetidemill.org.uk](http://woodbridgetidemill.org.uk)

# CONTENTS

- 3 Welcome
- 4 Introduction
- 5 Tide Mill timeline
- 6 The River Deben
- 7 How a tide mill works
- 8 Tide Mill machinery
- 11 Pit floor
- 12 Stone floor
- 14 The millstones
- 15 Crown floor
- 16 Sack hoist
- 17 The miller's log book
- 17 Flour dresser
- 18 Memories of the Mill
- 19 Primary programmes of study
- 20 From grain to mouth
- 21 Problem solving
- 23 A new film for the Tide Mill
- 25 Key Stage 3 and 4
- 26 Visiting the Tide Mill
- 27 Local places of interest
- 28 Contact



# WELCOME

**Thank you for looking at this resource pack for Woodbridge Tide Mill. We feel it will be of practical value in preparing for lessons which relate to the mill. Learning areas include a variety of important elements in modern education - History, Technology, Geography and the Environment including Sustainability with plenty of scope for projects, cross-curricular learning and research. We would love you to visit the mill as a school group, and an experienced guide will deepen understanding and engage the students to think about the building, its role in the community, its technical ingenuity and timeline, and also provide an opportunity to appreciate the surrounding Area of Natural Beauty (AONB).**

Michael Weaver (1941 - 2012)

The Tide Mill Trust is immensely grateful for the committed hard work and thorough research by Mike Weaver, lifelong teacher and mill enthusiast. This invaluable contribution provided detailed planning and exciting information, and a strong basis for the high quality educational offer we can now give.



# INTRODUCTION

The story of local farming and bread cannot be told without reference to mills, and the Woodbridge Tide Mill is a fine example of a corn grinding mill. Ideas that emerge from a visit to the Tide Mill or a study-project on the mill can be diverse and stimulate lateral thinking. The Tide Mill is a reflection of national history and also contains evidence of the influences of global factors. The time line embraces changes and events which include the dissolution of the monasteries, the onset of the Industrial Revolution (the present building dates from 1793), revolution in transport - river trade, railways and motor transport, the replacement of old technologies in the twentieth century, and the introduction of the leisure industry of modern times.

The Tide Mill offers a valuable opportunity for students to investigate changes in the use of the building and enables problem solving and imaginative discussions. Other areas of fascination include; technology as the Tide Mill is a definitive example of harnessing tidal power, the use of natural materials and the craftsmanship employed, the concept of moon power in a world running out of fuel resources, economics, community and business – running a small enterprise which relates to its locality in difficult times.

Mike Weaver 2011



# TIDE MILL TIMELINE

Milling is an ancient craft. For centuries the skills of the miller were vital to local communities and the mill was a central part of village life. Millers were not always seen in a good light, sometimes overcharging or taking more than their share of corn. A traditional rhyme alludes to this:

## THE JOLLY MILLER

*There was a jolly miller  
and he lived by himself,  
As the mill went round  
he gained his wealth,  
One hand in the hopper  
and the other in the bag,  
As the mill went round,  
he made his grab.*

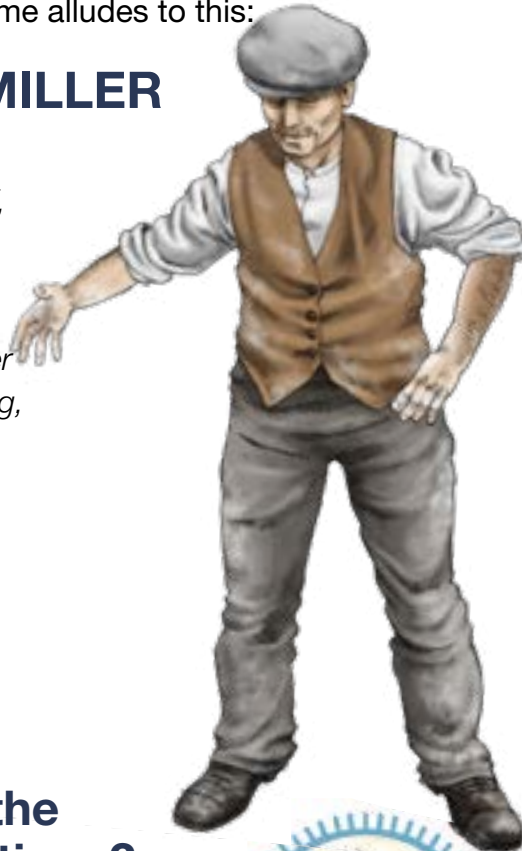

**Change and continuity.**  
Change of use from a corn grinding mill to a place for leisure and education. Research the circumstances which brought this about.



**Can you find the Royal connections?**

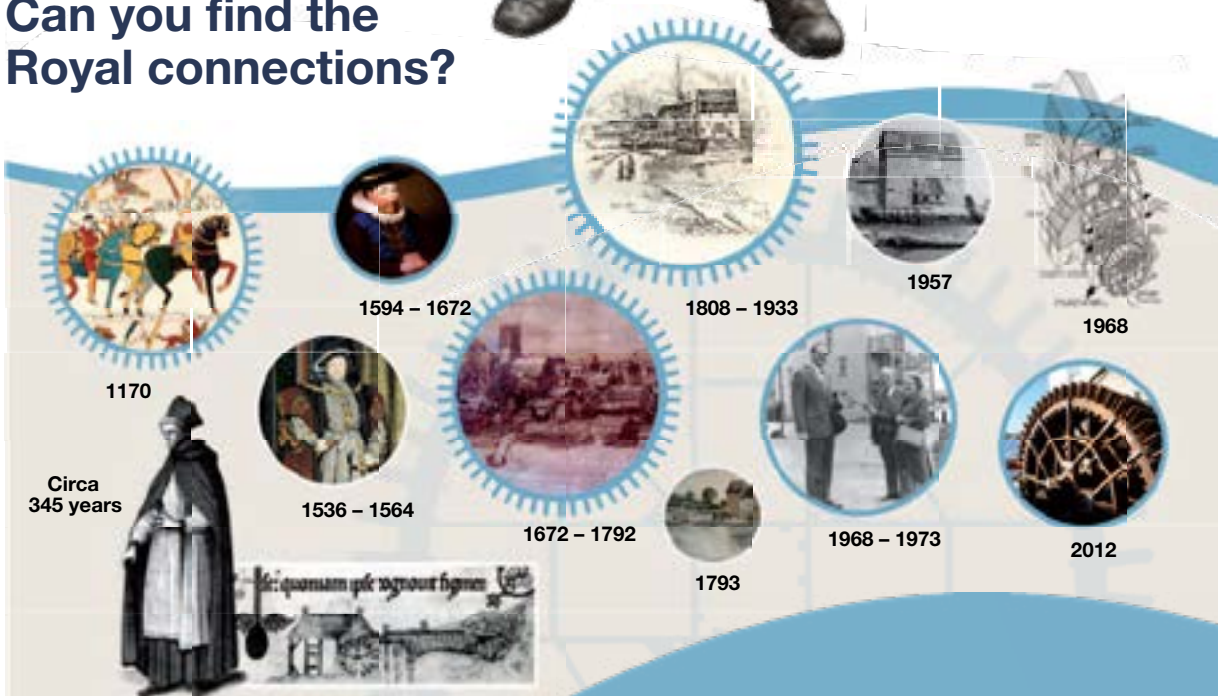

# THE RIVER DEBEN

**The Deben River is an estuarine river with high and low tides.**

## TIDAL POWER

Tide mills depended on the trapped water of the tide for their power. These mills were usually situated in shallow creeks, like the River Deben, and had large ponds to hold the water of the incoming tide, which entered the pond through gates that opened inwards.



### **Harnessing tidal power.**

**The skills and the ingenuity of medieval craftsmen trapping the tide to use its power. The same principles work today, 800 years later. Should we use more tidal power today, a great source of predictable sustainable energy?**



**Why is the River Deben ideal for the Tide Mill?**



# HOW A TIDE MILL WORKS

## **‘Twice a day the mill pond takes a gulp of the incoming tide’**

The pond at Woodbridge was just over 7 acres, and as the tide came in the pressure of the water opened the sluice gates in the bank and filled the pond. As the tide began to fall, the first water leaving through the sluice gates actually closed them. The weight of the trapped water kept them closed. Then when the tide had gone out sufficiently and there was no tidal water under the great water wheel, the miller opened the gates by the wheel and the water rushed out and turned the waterwheel. The gentle lapping of the tide coming in or going out would not have turned a great wooden wheel. It needed the greater force of the trapped water falling against the water wheel to turn it, allowing the mill to work for two hours each side of the low tide.



# TIDE MILL MACHINERY

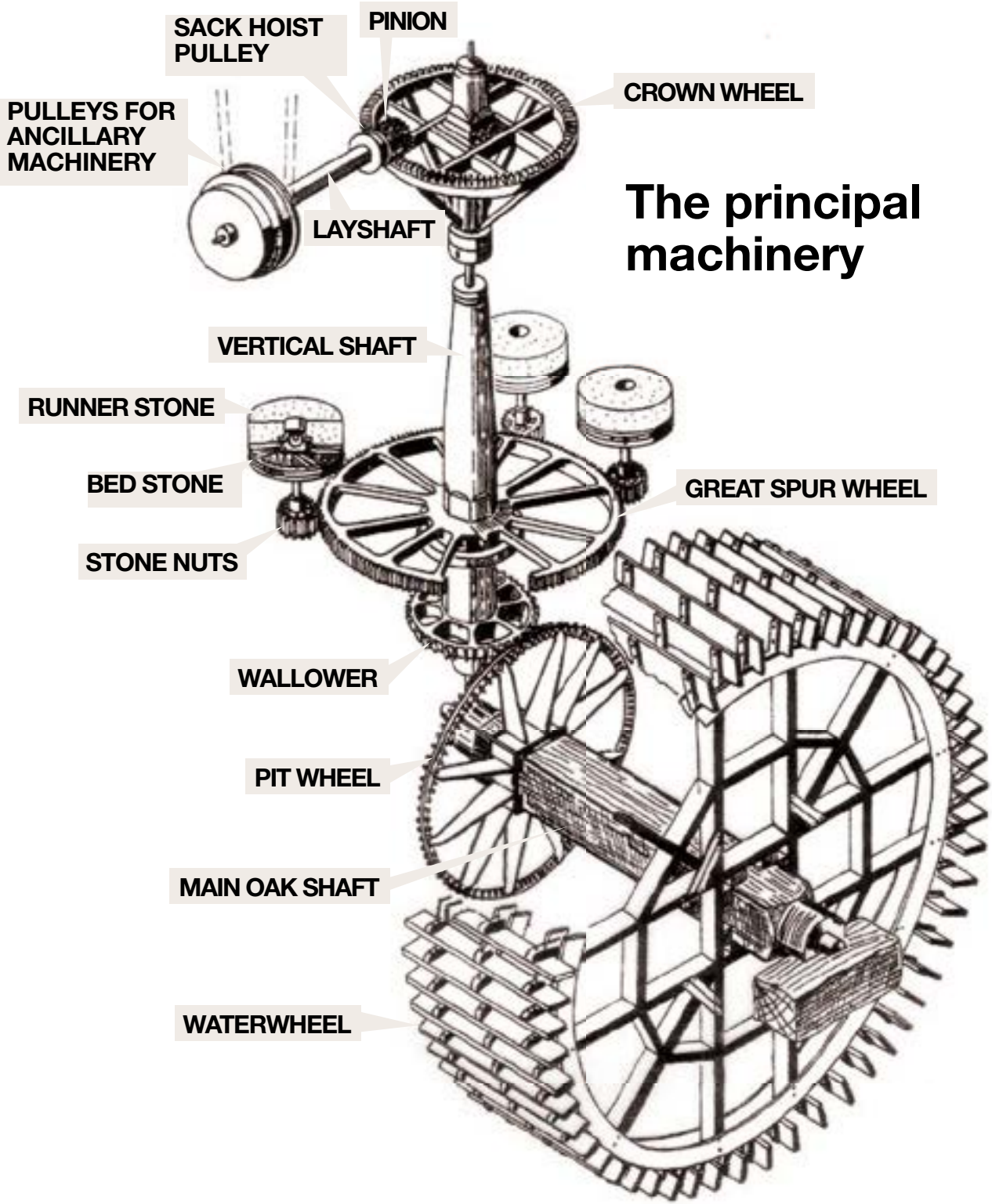



## **WATERWHEEL**

The English oak waterwheel is 4.96m (16ft 4in) in diameter and 1.5m (4ft 11in) wide and has 56 float boards 30mm (1.2in) thick and 390mm (15.3in) wide and is mounted on a 600mm (23.6in) square oak shaft.



## **GOVERNOR**

A centrifugal governor is commonly used in windmills to compensate for varying wind speeds by adjusting (centering) the gap between the millstones. Wood-bridge Tide Mill is unusual in having a governor but this was probably the result of millwrights trying advanced techniques to allow for changes in the flow of water as the pond emptied, slowing the waterwheel.



## **PIT WHEEL**

A cast iron wheel on the oak shaft of the waterwheel, cast as four sections, and with 104 wooden teeth.



## **WALLOWER**

The wallower is a cast iron wheel that meshes with the pit wheel and transfers the power from the waterwheel to the main vertical shaft.



## **GREAT SPUR WHEEL**

The millstones are driven from below from the great spur wheel by small pinions called stone nuts. These are mounted on vertical iron spindles which turn the upper millstones.



## MILLSTONES

Millstones work in pairs, a fixed lower, or bedstone, and a top or runner stone that turns above it, creating the grinding action. The runner stone is carried on a rynd or bridge, a shaped metal bar fitted across the eye of the runner stone, which sits in a mace, a fitting on the head of the millstone spindle.



## STONE NUTS

Small cast iron cogs with wooden teeth that drive the wrought iron shafts supporting and turning the runner stones. Stone nuts can be raised by means of a crank which pushes them up a slotted collar on the shaft so that they disengage from the great spur wheel. They are only engaged/disengaged when the machinery is stationary.



## CROWN WHEEL

Drives are taken from the crown wheel to ancillary machinery via the layshaft.



## LAYSHAFT

Driven by the crown wheel, the layshaft allows the miller to power the sack hoist and flour dressing machine.



## SACK HOIST

Driven from the layshaft this ingenious mechanism, controlled from the ground floor, allows the miller to lift sacks of grain and flour up to the upper floors.



# PIT FLOOR

## THE PIT WHEEL

This sits on the same axle as the waterwheel. It is a cast iron wheel on the oak axle of the waterwheel. It has 104 wooden teeth.



## THE WATERWHEEL

Made of English oak, the waterwheel was assembled directly onto the oak axle from prefabricated sections. It is driven in the undershot mode by the force of flowing water striking the float boards at the bottom of the wheel, and rotates at five revolutions per minute (rpm).

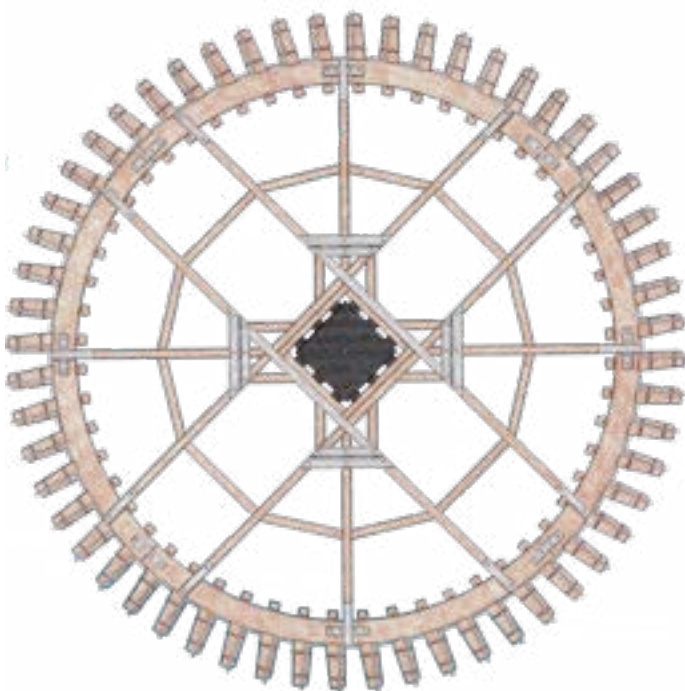

**The incoming tide fills the mill pond, what happens next?**

# STONE FLOOR

## THE GRINDING PROCESS

The grain is induced to flow into the centre (eye) of the runner stone by vibrating the sloping trough (slipper or shoe) with the rotating damsel. The rotation of the runner stone over, close to but not touching, the stationary bed stone, crushes the grain by a scissor-like action of the grooves cut in the stones' surfaces. The flat areas (lands) of the stones further reduces the particle size.

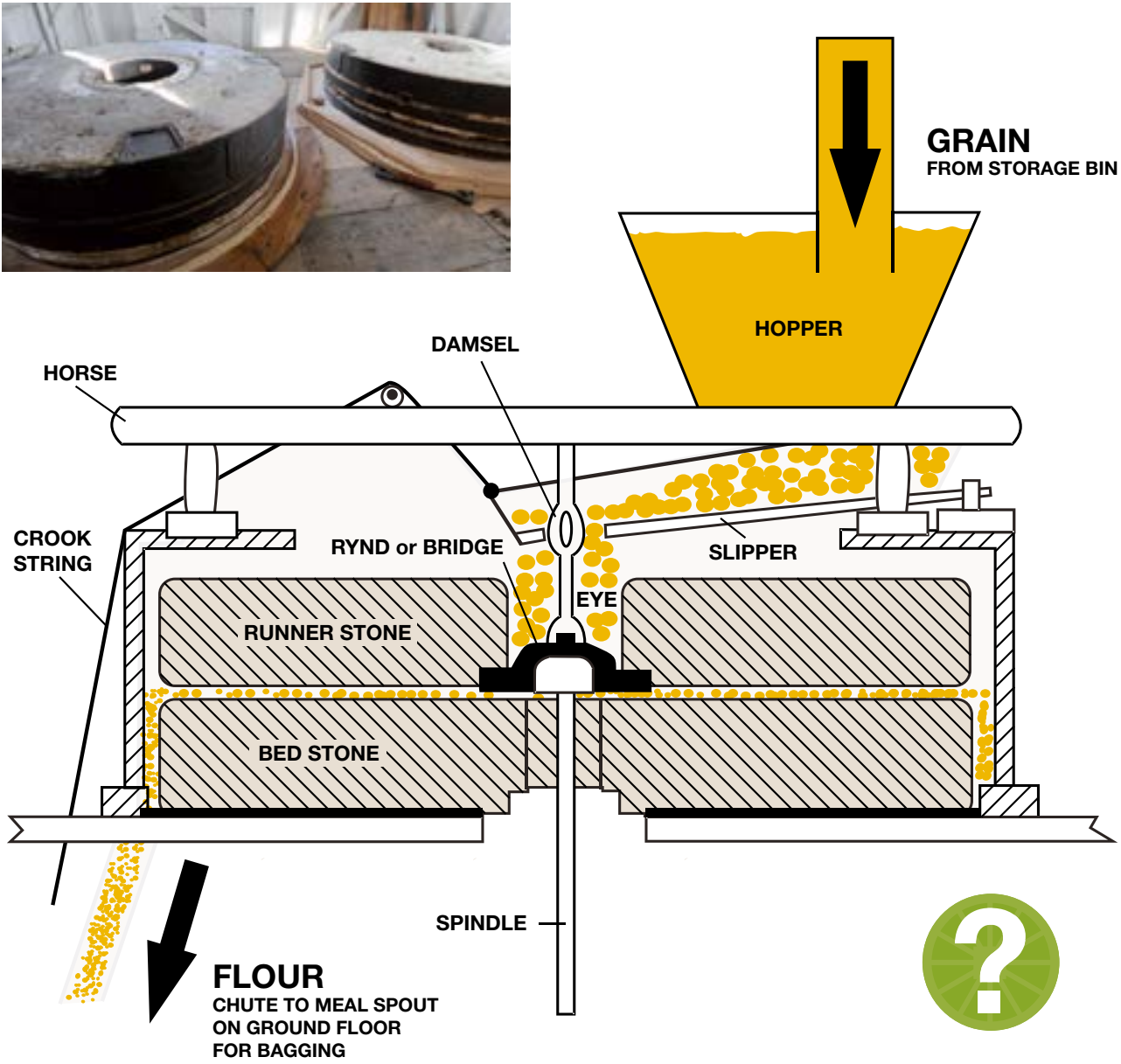

Why did the Miller use a bell?



## DAMSEL

Mounted on the top of the millstone spindle, the rotation of the damsel shakes the shoe and induces the grain to flow into the central hole (eye) in the runner stone. It is often said that the damsel is so called because of its constant chattering when the mill is grinding. An alternative view is that when milling was done by hand, as part of the domestic routine, feeding in the grain was done by a young female member of the family.



## TUN

A circular or octagonal wooden case is used to cover the millstones and retain the meal that is produced prior to it being swept into a spout to the ground floor. It also provides a platform for the horse, a frame that supports the hopper and feed shoe.



## BELL

A bell was used to give the miller early warning that the feed hopper was running low. A cord attached to the springy bell support was buried under grain in the hopper and this restrained the bell from ringing. If the cord was not buried by grain the bell was free to ring.

# THE MILLSTONES

The 'harp' pattern of grooves induces the flour flow to the outer rim of the stones where it is swept by paddles into a chute leading to the ground floor and bagging.

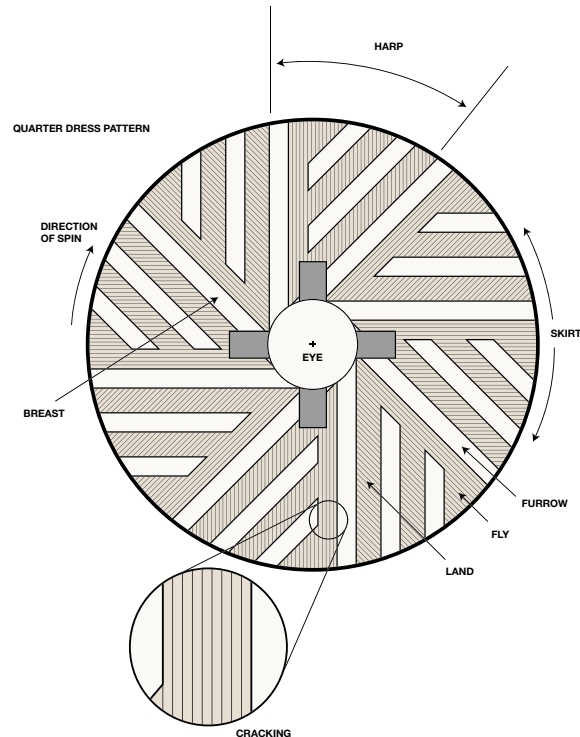

## DRESSING THE STONES

Dressing of millstones is one of the most important aspects of mill maintenance. The inner surfaces of the millstones have a harp pattern of grooves cut into them, the runner stone and bed stone grooves are cut in opposite directions to give the grinding action. The alignment of the stones is vital to evenly ground flour.



**Why were the stones balanced carefully?**

# CROWN FLOOR

## THE CROWN WHEEL

This operates the sack hoist. As the crown wheel turns so the pinion turns, and pulleys power the sack hoist. Sacks of grain are raised to the top floor (the next floor up from the crown floor) and poured into vermin-proof storage bins, and then flow down a spout to the hopper to feed a shoe above each pair of millstones.



Corn bin

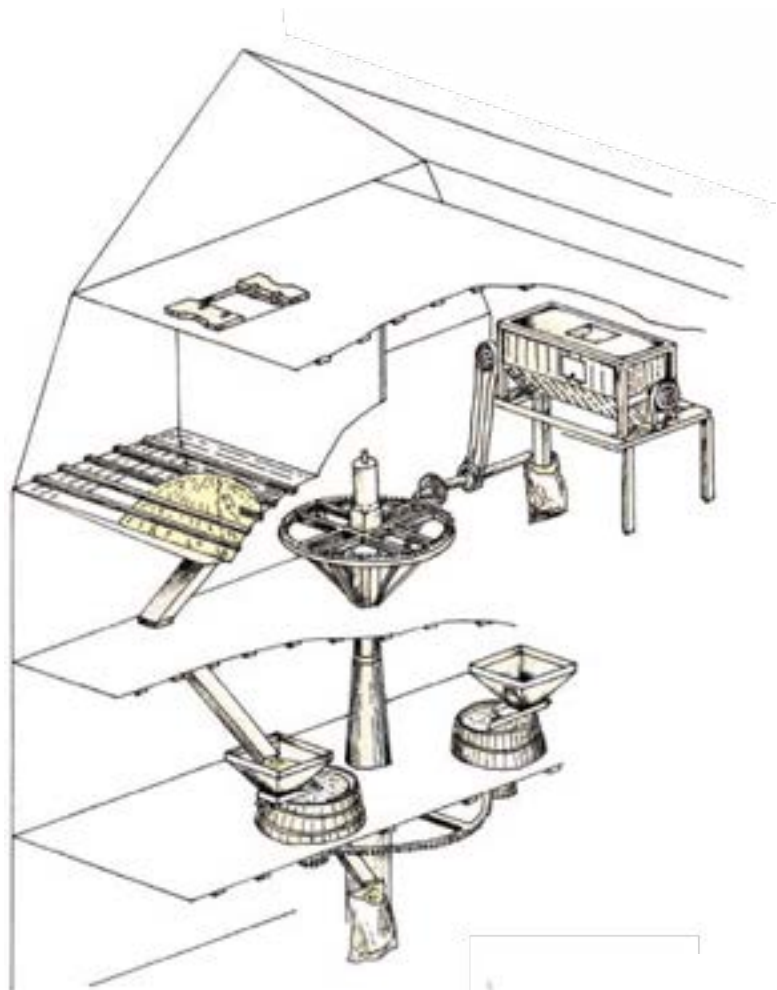

**Why does a sack travel upwards instead of down?**



# SACK HOIST

The sack hoist is a vital mechanism used to lift sacks of grain or flour from the ground level either through the lucam or the centre of the mill and the hatches on each floor. Bear in mind that some sacks would weigh in excess of 100kg (2cwt).

The sack hoist is powered by the layshaft and lifts the grain to the top of the mill. The grain then flows by gravity via a chute to a hopper above the millstones.



The lucam



The hatch



**How many sacks weigh the same as four children?**

# THE MILLER'S LOG BOOK

The miller's log books were used to record the type and quantity of each batch of grain, beans or peas, who the owner was, and the charge for milling the batch. They allowed the miller to keep a running total of how much each set of stones had been used and record income. Routine maintenance and running repairs would also be recorded.



**What would the Miller write in his log book?**

## FLOUR DRESSER

If white flour was required, the whole-meal flour was hoisted again to the top floor and fed into the flour dresser. The mill's dresser consists of a horizontal perforated cylinder lined with wire gauze of varying mesh size and with rotating brushes that sweep the flour along the cylinder. The graded flour falls into chutes for bagging and the coarse particles of bran emerge from the lower end of the dresser.



**How did the Miller remove bran from the flour?**

# MEMORIES OF THE MILL

A miller had to be familiar with all the complex machinery of his mill and be able to make running repairs. Most millers were able to dress or re-cut the stones to make them more effective cutting instruments again.

**Alfred Runnaces was my father and he worked at Woodbridge Tide Mill until 1929. When my father was away dressing stones at other mills we went down to feed the cats. He dressed the stones at the Tide Mill of course, using sharpening tools called mill bills, made of very hard steel, like a wedge-shaped hammer fitted onto a wooden handle. When the cogs of the wheel wore out Mr Clarke, a millwright, replaced them with cogs made of apple wood.**

(Ethel Wigg remembers)



Write an advertisement for the job of the miller. Include how hard the work was!

# PRIMARY PROGRAMMES OF STUDY

The Mill provides opportunities for learning in a range of subjects and cross-curricular work at Primary and Early Years Foundation Stage level. The setting provides a memorable experience for pupils to stimulate their learning at the Mill and within the school setting. We have worked with Suffolk Education Advisers and pilot schools to develop three initial programmes which provide relevant and valuable links to the curriculum and encourage active learning. Use of these programmes can be adapted to suit individual class and schools' interests and needs, with visits to the Mill and outreach sessions a part of the offer if desired. Within each programme there are pre-visit and post-visit learning opportunities listed which can broaden the learning experience. The programme outline has been designed to allow the freedom for a teacher to use the ideas within a lesson, topic or subject. From the programmes we have also developed lessons with learning objectives, presentations, a range of differentiated learning activities and extension work. We are able to work with schools and groups to achieve the most from the educational opportunities the Mill has to offer.



# FROM GRAIN TO MOUTH

## PRE-VISIT WORK

- Work around different grains and their flours – language, geography and science work.
- Taste various breads, including local bread and bread from different countries and cultures, analyse textures, smells and tastes.
- Grow some grain (one loaf of bread needs one square metre of grain) – Science.
- A farm visit, or a farmer to come into school.
- How do you turn grain into flour? Investigation – what materials, shape of stones are used?
- Record growth of the grain/crop – using ICT (time lapse photography).
- Links to children’s literature, e.g. ‘Little Red Hen’.
- Visit from Tide Mill staff to deliver some grain to grow, bake with the pupils and talk about breads and speciality breads like harvest loaves.
- Bread displays.
- Harvest and rural agricultural stories and rhymes.

## THE VISIT

- Pupils come in period dress with a period packed lunch and the grain grown in school.
- Grind the grain – either in the mill or a working model.
- Tour of mill and pond from ‘miller’ dressed in period costume.
- Use the flour made from their grain to make bread dough to knead and shape into loaf/rolls.

## POST-VISIT WORK

- Design a new loaf for the school and bake.
- Work on a healthy lifestyle and the part bread plays in this.
- Hold a ‘bread party’ in school and invite, parents, members of community and ‘miller’ into school.

Pupils organise the event (e.g. write invitations, think about venue, how to prepare it, bake the bread, raise funds to cover the costs).

During the event might entertain with poems, singing, results of any data analysis they have done. (e.g. best place to grow wheat in the school, preferred grain/bread type, preferred shape of loaf/roll, what people like spread on their bread.)

Pupils put up a display of all the work they have done linked to the project.



# PROBLEM SOLVING

## PROBLEMS TO SOLVE:

- Friction – how could you prevent sparks to stop the Tide Mill burning down?
- Materials – why has the Mill not rotted away yet?
- Movement – how can the movement of a vertical water wheel drive the horizontal grinding stones?
- Movement of heavy objects – how would you lift a heavy sack to the top floor of the Mill?
- Pest control – how could you stop an infestation of pests in the Mill?
- Time – how would you plan your working day if you were the miller?

## PRE-VISIT WORK

- Staff from the Tide Mill visit the school and introduce the problems that the pupils are going to solve and provide information, diagrams and photographs.
- Pupils identify and research problems that might need to be solved if they were running a tide mill.
- Plan questions to ask the visitors and design posters.
- Pupils explore ways to solve problems through a series of dramatic investigations and stories.

## THE VISIT

- Pupils tour the mill to see how the problems have been solved. Pupils record the solutions to the problems using photography or sketching where appropriate.

## POST-VISIT WORK

- Pupils produce an evaluative PowerPoint presentation comparing their own initial solutions with the actual ones seen at the mill. This could include photographs of investigations carried out before the visit as well as sketches and images recorded during the visit.
- Pupils select PowerPoint presentations to send back to the mill or mill website for possible display.

# NATIONAL CURRICULUM LINKS

## Key Stages 1 & 2

The National Curriculum is organised into blocks of years called 'key stages' (KS).

Stages 1 & 2 are detailed here: -

<https://www.gov.uk/national-curriculum/key-stage-1-and-2>



# A NEW FILM FOR THE TIDE MILL

## POSSIBLE SECTIONS FOR THE FILM:

- The Past, The Present, The Future. What can we learn from the Mill that links to sustainability, alternatives to road transport and change? How the Mill works.

## PRE-VISIT WORK

- Pupils work with pre-visit pack from the Tide Mill which contains old photographs and reproductions of art work from the past and today.
- Work around chronology (e.g. ordering images of the mill from oldest to newest), identifying similarities and differences between old photographs and the present day, and formulating enquiries.
- Watch the old film of the Tide Mill from 'The Shell Film Unit – Craftsman Series' (provided on a DVD by the Tide Mill) and set the pupils the challenge of making an up-to-date version in the style of a 'Horrible Histories' production.
- Pupils design and plan story boards to decide upon the sections that their short film will have (see box above).
- Pupils prepare questions to ask on the visit so they get the information they need for their video. They could turn this into an interview they film while on the visit.
- Pupils plan what they will need to take photographs/film of during the visit and what props/costumes will be needed.

## THE VISIT

- Pupils have a tour of the mill. This will include time for interviewing the staff, taking notes (possibly by audio recording), photographing and sketching the mill.
- 'What is not part of the past?' activity. Pupils decide on a time period in which their film will be set and look around the mill and the surroundings to identify what objects would need to be removed to turn it into a film set (e.g. fire extinguishers, light switches, double yellow lines).
- This could be done by taking photographs with a digital camera and annotating them back at school).
- Pupils will film scenes that will be part of their final video (could bring props and costumes).
- *The school to provide digital cameras and video cameras for the work at the Tide Mill.*

## POST-VISIT WORK

- Pupils review all the information they collected during the visit and decide which to include. Edit and refine idea. Pupils carefully select 3 images from the pre-visit pack from the tide mill (which contains old photographs and reproductions of art work), to include in their work.
- Pupils make their video in the style of a 'Horrible Histories' production.
- The video could include filming undertaken during the visit, their digital photographs, and sketches they have drawn that have been scanned into the computer.
- *The film could be made using PhotoStory 3 (KS1) or Windows Movie Maker, or similar (KS2).*
- Persuasive writing – pupils write a letter to the producers of 'Horrible Histories' to try and get their video included in the next series.
- Hold a premiere to launch the new videos of the tide mill.
- Pupils can organise all aspects of this – decide who to invite (hopefully including staff from the tide mill), write invitations, think about venue, how to prepare it, raise funds to cover the costs, etc.

## NATIONAL CURRICULUM LINK

### Government Key Stages 1 & 2

The National Curriculum is organised into blocks of years called 'key stages' (KS).

Stages 1 & 2 are detailed here: -

<https://www.gov.uk/national-curriculum/key-stage-1-and-2>

## PLEASE LEAVE FEEDBACK

Woodbridge Tide Mill Museum is an Arts Council Accredited Museum. It survives by getting entry fees and grants.

Grant providers want to see customer feedback before making grants. For this reason, and to help us improve, please help us by providing feedback.

- Ask students to **write letters** (or **emails** *but old fashioned letters are best?*) in response to their visit. What they liked, disliked, things they learned - most striking recollection etc.
- Adding sketches of the Mill or photos, inside and out, adds colour to a review.
- Please provide a review on [Google](#) or [TripAdvisor](#). An 855 year old Mill reviewed on modern media!
- Post pictures or video of the Mill taken during your visit (or class if you visit virtually) to your social media channels and tag **#woodbridgetidemillmuseum** **#woodbridgetidemill**.



# KEY STAGE 3 AND 4

The Tide Mill offers many opportunities for study in GCSE and A level in subjects such as Social and Economic History, Local History, Design and Technology, Geography and Business studies.

We are developing valuable learning programmes for KS3, KS4 and adult learners. These programmes of study will include 'change and continuity', harnessing tidal power, comparative studies of energy, site visit skills, bio-diversity and the learning opportunities provided being situated in an Area of Natural Beauty.

We would like to develop this potential with schools, so please do contact us.

Stages 3 & 4 are detailed here: -

<https://www.gov.uk/national-curriculum/key-stage-3-and-4>



# VISITING THE TIDE MILL



## Entry Fee

Adult (16+) - £6.00  
Concession - £5.00  
Accompanied Child (5-15yrs) - £3.00  
Family (up to 2 adults & 2 Children) - £15.00  
Visitors with access limitation - Free

## Education Groups

Price per pupil: £3  
Coach drop off at the entrance to  
Tide Mill Way

## Opening Times

We are open from April to November every day from 11am – 5pm  
There is a calendar of wheel turning times on the website 'Plan Your Visit' page  
It is recommended that you allow up to 2½ hours to visit the Mill's three floors and  
outside area

# LOCAL PLACES OF INTEREST

## **SUTTON HOO**

(distance from mill - 3 miles)

Tranmer House, Woodbridge

Website: [www.nationaltrust.org.uk/sutton-hoo](http://www.nationaltrust.org.uk/sutton-hoo)

Email: [suttonhoo@nationaltrust.org.uk](mailto:suttonhoo@nationaltrust.org.uk)

Tel: 01394 389700

In 1938 when the grounds of Sutton Hoo were excavated, the 90 foot ship burial of an Anglo-Saxon king was dug up and was declared a great find in England. Among the findings were gold, silver, iconic helmets and other treasures.

## **WOODBIDGE MUSEUM**

(distance from mill - 500m, 5 minute walk)

## **LONG SHED - SHIP'S COMPANY**

(distance from mill - 500m, 5 minute walk)

## **WOODBIDGE PLAYING FIELDS AND BOATING POND**

(distance from mill - 0.5 mile, 5 minute walk)

## **BUTTRUMS MILL**

(distance from mill - just over 1 mile, 15 minutes walk)

## **RIVER DEBEN WALK**

(distance from mill - 0 miles)

# CONTACT

## Bee Farrell

Email: [education@woodbridgetidemill.org.uk](mailto:education@woodbridgetidemill.org.uk)

Personal Tel: 07712 651213

Tide Mill Tel: 01728 746959